

MIDDLETON SOLAR  
16 WILSON AVENUE BRUNSWICK VICTORIA 3056 AUSTRALIA

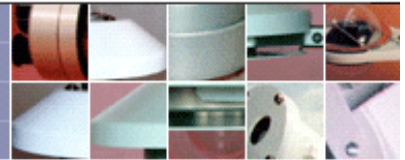

## EQ08-S & EQ08-SE PYRANOMETER

Secondary Standard Pyranometer for Solar Global Radiation



The Middleton EQ08-S is a precision pyranometer for the measurement of global solar irradiance on a plane surface. It exceeds the international accepted specifications for a high quality pyranometer. The EQ08-S incorporates a second generation precision thermoelectric sensor that has exceptionally low directional error without compromise to signal strength or response time. The EQ08-SE version has an in-built amplifier to give a millivolt output for easy signal measurement.

Performance Specification	ISO9060 Secondary Standard	EQ08-S, SE (typical)
Response time (to 95%)	< 15s	13s
Zero off-set: a) 200 W.m <sup>-2</sup>	+ 7 W.m <sup>-2</sup>	< + 6 W.m <sup>-2</sup>
b) 5K.h <sup>-1</sup>	± 2 W.m <sup>-2</sup>	< ± 1 W.m <sup>-2</sup>
Non-stability (per year)	± 0.8%	< ± 0.5%
Non-linearity (100-1000W.m <sup>-2</sup> )	± 0.5%	< ± 0.5%
Directional response (w.r.t. 1000 W.m <sup>-2</sup> )	± 10 W.m <sup>-2</sup> (30-80°)	< ± 10 W.m <sup>-2</sup> (0-85°)
Spectral selectivity (0.35 to 1.5µm)	± 3%	< ± 2%
Temperature response (for 50K interval)	± 2%	< ± 0.5%
Tilt response (0-90°)	± 0.5%	< ± 0.2%

### OUTSTANDING DIRECTIONAL RESPONSE, STABLE, DURABLE

Marine grade aluminium, hard anodized for corrosion resistance.

Bubble level on top of instrument for easy viewing.

Fully sealed construction for low-maintenance.

Strong output signal.

## Middleton Solar EQ08-S & EQ08-SE Pyranometer Detailed Specification

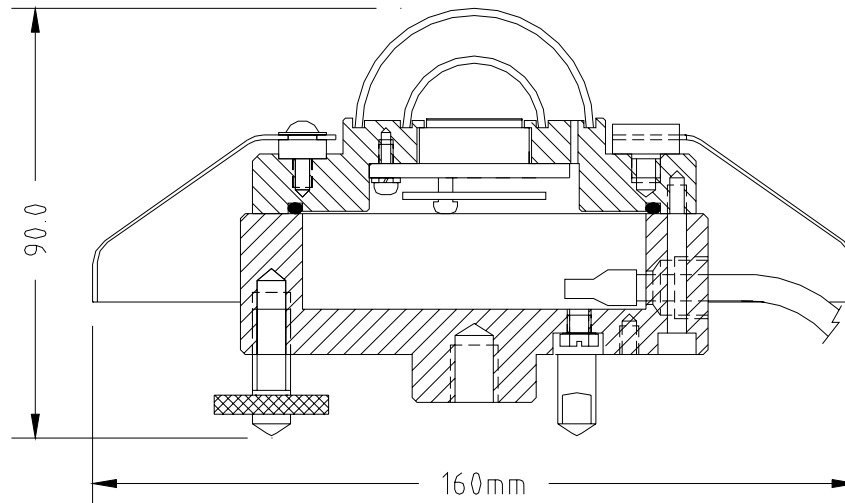

Exceeds the ISO9060 specifications for a Secondary Standard Pyranometer.
Temperature compensated thermopile sensor has flat spectral response.
The EQ08-S has a passive microvolt output, and the EQ08-SE version has an in-built signal amplifier to give a millivolt output for easy measurement.
Metal shade disc is thermally insulated from the body.
Plastic feet thermally insulate instrument from mounting structure.
Fully sealed to IP66, with no need to periodically inspect internal desiccant.
Optional thermistor output for sensor temperature is available.
Dual glass domes protect the sensor from air temperature fluctuations.
Supplied with simple mounting kit.
User's Guide and Calibration Certificate included.

### General Specification

viewing angle	$2\pi$ steradians
irradiance	0 - 4000W/m <sup>2</sup>
spectral range	300 - 3000nm (nominal); 305 - 2850nm (50% points)
sensitivity (typical)	EQ08-S: 17 $\mu$ V/W.m <sup>-2</sup> ; EQ08-SE: 1.0mV/W.m <sup>-2</sup>
calibration accuracy	$\pm$ 2% (factory certificate, traceable to WRR)
impedance	EQ08-S: 40 $\Omega$ ; EQ08-SE: 100 $\Omega$
power requirement (EQ08-SE only)	5.5-14.5 VDC; 6mA
operating temperature	-35 to +60°C
operating humidity	0-100% RH
bubble level resolution	0.1°
level adjustment	one fixed foot, two adjustable feet
desiccant	orange silica gel (non-toxic)
mounting method	central M10 hole in base, plus pair M4 holes on 65mm P.C.D.
output lead	6m
shipping size & weight; net weight	230 x 230 x 180mm, 2Kg; 0.8Kg

Another variation of the EQ08-S is also available: the EQ08-SA. It has active infra-red offset compensation in addition to an in-built signal amplifier.

Available from: